



MODEL 621

Convection is the ideal way to cook foods evenly and quickly. This oven features a 3 step bake process with ten programmable presets to make your baking process simpler. Heated, circulating air throughout the oven penetrates food quickly. Perfect for everything from cookies, muffins, and biscuits to frozen snacks and hors d'oeuvre.

FEATURES:

- Quick, easy 3 step bake process with 10 programmable presets
- Precise temperature and adjustable time control
- High speed fan for even air distribution
- Baking temperatures ranging from 150°F-500°F
- Stainless steel construction
- Insulated, double wall construction
- Removable door and rack supports for easy cleaning
- Unit comes with (3) Wire Racks and (3) 13½" x 10" Aluminum Baking Trays
- Able to accommodate (3) standard ¼ size sheet pans (*Not Included*)
- Will accommodate most 9" x 13" pans depending on the height and style of the lip/rim

ACCESSORIES:

- 00620PS3 - 3 Aluminum Baking Trays Boxed Set
- 0022693 - 500 Count Parchment Paper
- 0022694 - 1000 Count Parchment Paper
- 0022840CR - Cooling Rack Kit

ELECTRICAL DATA:

VOLTS:	120	AMPS:	10.9	WATTS:	1300
---------------	-----	--------------	------	---------------	------

- Best when operated on an individual branch circuit
- Approx. 57" NEMA 5-15 Power Cord

NEMA 5-15P

DIMENSIONS:

- External: 19"W x 18"D x 14 ¼"H
- Internal: 14"W x 11"D x 8-5/8"H
- ACTUAL WEIGHT: 36 lbs.

SHIPPING INFORMATION:





- SHIPPING DIMENSIONS: 23"W x 25"D x 18"H
- SHIPPING WEIGHT: 47 lbs.



WARNING: These products can expose you to chemicals including Nickel (Metallic) which are known to the State of California to cause cancer. For more information go to www.P65Warnings.ca.gov

FP140218 REV: ORIG

IMPORTANT: Read the following safety and operation instructions to avoid damage to equipment or property.

-  Plug unit into a properly grounded electrical outlet of the correct voltage, size, and plug configuration for this unit. We recommend usage on an individual branch circuit of at least 15 amps for best results. Failure to do so may result in decreased performance of the warmer.
-  The oven should never be operated on or near combustible materials. Caution should be taken because the hot surfaces attained during use.
-  Exterior surfaces on unit may get hot. Use caution when touching these areas to avoid injury.
-  Unplug warmer when not in use.

INITIAL START UP

Before you use your new Wisco 621 Convection Oven, you will want to follow the steps listed below in order to get rid of any oil, film, etc. that may still be on the oven from the manufacturing process.

The unit may initially smoke during this process.

- Clean the oven with a mild detergent inside & out
- Set the oven's temperature control board to 400°F
- Allow the oven to run for approximately 60 minutes
- After this cycle, you are now ready to start cooking

OPERATING INSTRUCTIONS

TEMPERATURE

Most products require lower temperatures than suggested for deck or range ovens. A standard temperature reduction of 25°F-30°F is recommended as a starting point. Actual baking will vary pending product weight and consistency. If the edges of the product are done and the center is still raw or there is extensive color variation, reduce the thermostat setting by 15°F-25°F until the desired results are achieved. Excessive temperatures will not reduce baking time.

TIME

Convection ovens generally bake 20% faster than deck or range ovens even though lower temperatures are used. Most recipes can be converted by having shorter cooking times and/or reducing your cooking temperatures.

- Frozen food products will require more time than refrigerated products
- 3 trays of food product will take more cook time than 1 tray of food

PRODUCTS

Load the oven from the bottom up. To ensure even baking, equal amounts of products should be used. Different amounts of product in different pans can cause uneven baking.

- We suggest a clearance of 1-3 inches between pans when cooking for proper air circulation and best results.

OPERATING INSTRUCTIONS

- General Description:
 - The 621 Convection oven offers manual control of TIME and TEMPERATURE settings
 - The TIME can be adjusted in 30 second increments
 - The TEMPERATURE can be in 5° F increments
- Programming:
 - Press ON/OFF
 - To program the oven, hold PROGRAM button until a beep sounds
 - Using arrows choose the preset you desire to program, P1, P2, P3, etc. then press SELECT
 - Adjust your TIME, then press SELECT
 - Adjust your TEMPERATURE
 - Once TIME and TEMPERATURE are selected, hold PROGRAM to exit out until a beep sounds verifying program exit mode
 - Presets will remain in memory even if the oven is unplugged
- Baking:
 - Choose the preset you require for baking
 - Press START/STOP to begin PREHEAT
 - While the oven is preheating, the PREHEAT light will flash
 - Preheating TEMPERATURE will rise in 5° F increments
 - Once preheated insert baking goods and press START/STOP to begin the timer
 - You can repeat process of baking by pressing START/STOP
 - If re-baking on same preset, PREHEAT will be skipped and continue to TIME
 - You may increase or decrease bake time in 30 second increments during the bake cycle

CLEANING INSTRUCTIONS



Unit is not waterproof. Do Not submerge in water. Do not operate if unit has been submerged in water.



Unplug unit from power source and allow to cool completely before performing any maintenance or cleaning.

The inside of the oven can be cleaned with a mild detergent, water, and a soft cloth. Do not use acids or caustic products such as foaming oven cleaners.

Pans, racks and support racks are easily removed for cleaning with a mild detergent, water and soft cloth. To remove support racks, simply lift up and out.

The outside of the oven can be cleaned with a mild detergent, water, and soft cloth. You may also use a stainless steel cleaner.

AVOID USING ABRASIVE/SCOURING PADS AS SOME MAY CAUSE SCRATCH MARKS ON YOUR UNIT.



DESCRIPTION

This document illustrates how to remove/replace the Oven Door for models 620, 621, & 721.

- 1** Unplug the unit and then open the door.



- 2** Push HINGE LOCKS in "up/locked" position.

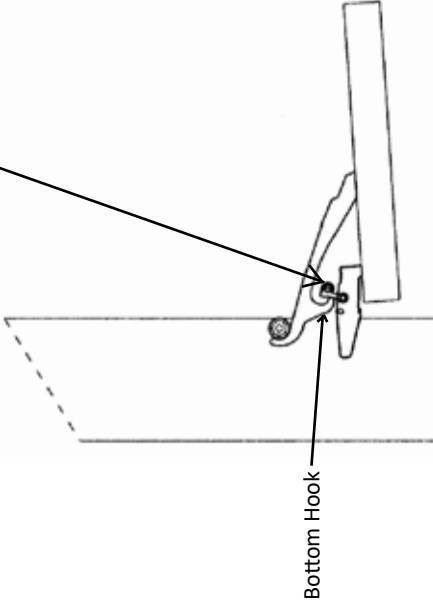
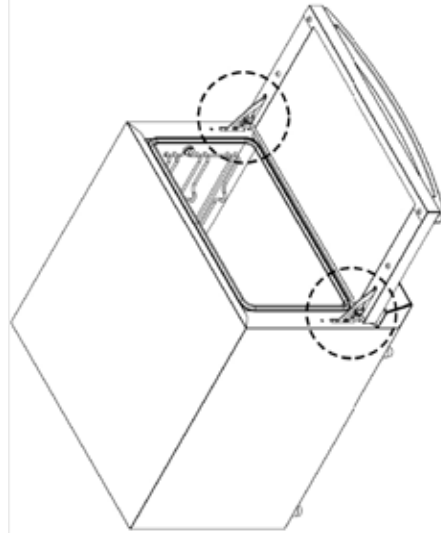

Bottom Hook

- 3** Tilt door up at about 45° angle until the TOP HOOK on HINGE ARM is lower than the TOP HOOK ROLLER; pull door out of HINGE SLOTS.

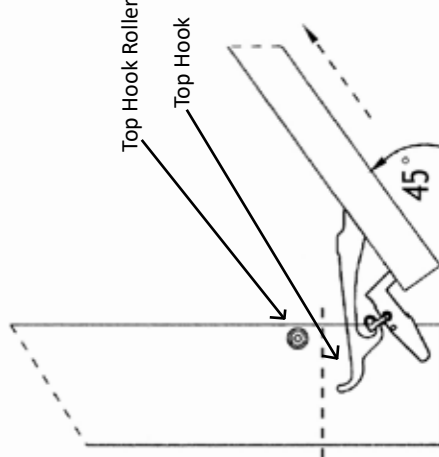

TO REPLACE DOOR

- 1** Reference step 3 above in reverse for placing door back into the unit.

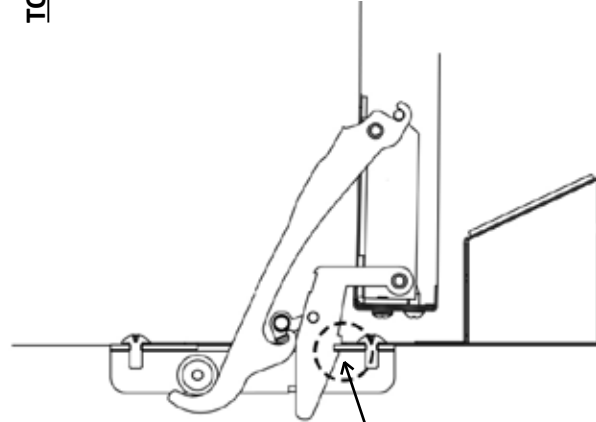

- 2** Ensure notch is secured in position shown.

- 3** In order to put HINGE LOCKS in "down lock" position, slight downward pressure on door may need to be applied to release HINGE LOCKS.

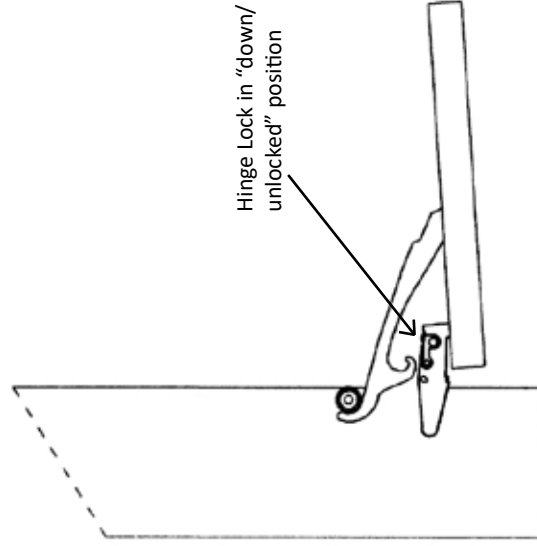

Hinge Lock in "down/unlocked" position

PARTS LIST:**MODEL 621**

ITEM #	PART#	DESCRIPTION
1.	0022670	COOKING RACK
2.	0022679	COOKIE TRAY
3.	0022676	INTERNAL SUPPORT RACK
4.	0022691	INTERNAL SUPPORT SCREW
5.	0027429SK	DOOR ASSEMBLY SERVICE KIT
6.	0027439SK	CONTROL PANEL ASSEMBLY SERVICE KIT
7.	0027426	DOOR GASKET
8.	0023057SK	BOTTOM FOOT SERVICE KIT
9.	0016180	STRAIN RELIEF
10.	0022666	POWER CORD
11.	0027391SK	TEMPERATURE SENSOR
12.	0022662	FAN BLADE
13.	0022663SK	HEATING ELEMENT
14.	0027192	HI-LIMIT THERMOSTAT
15.	0022687SK	BLOWER MOTOR
*	0022693	500 COUNT PARCHMENT PAPER 620/621
*	0022694	1000 COUNT PARCHMENT PAPER 620/621
*	0022840CR	COOLING RACK
*	00620PS3	3 COOKIE PANS BOXED SET 620/621

MODEL 621 EXPLODED VIEW

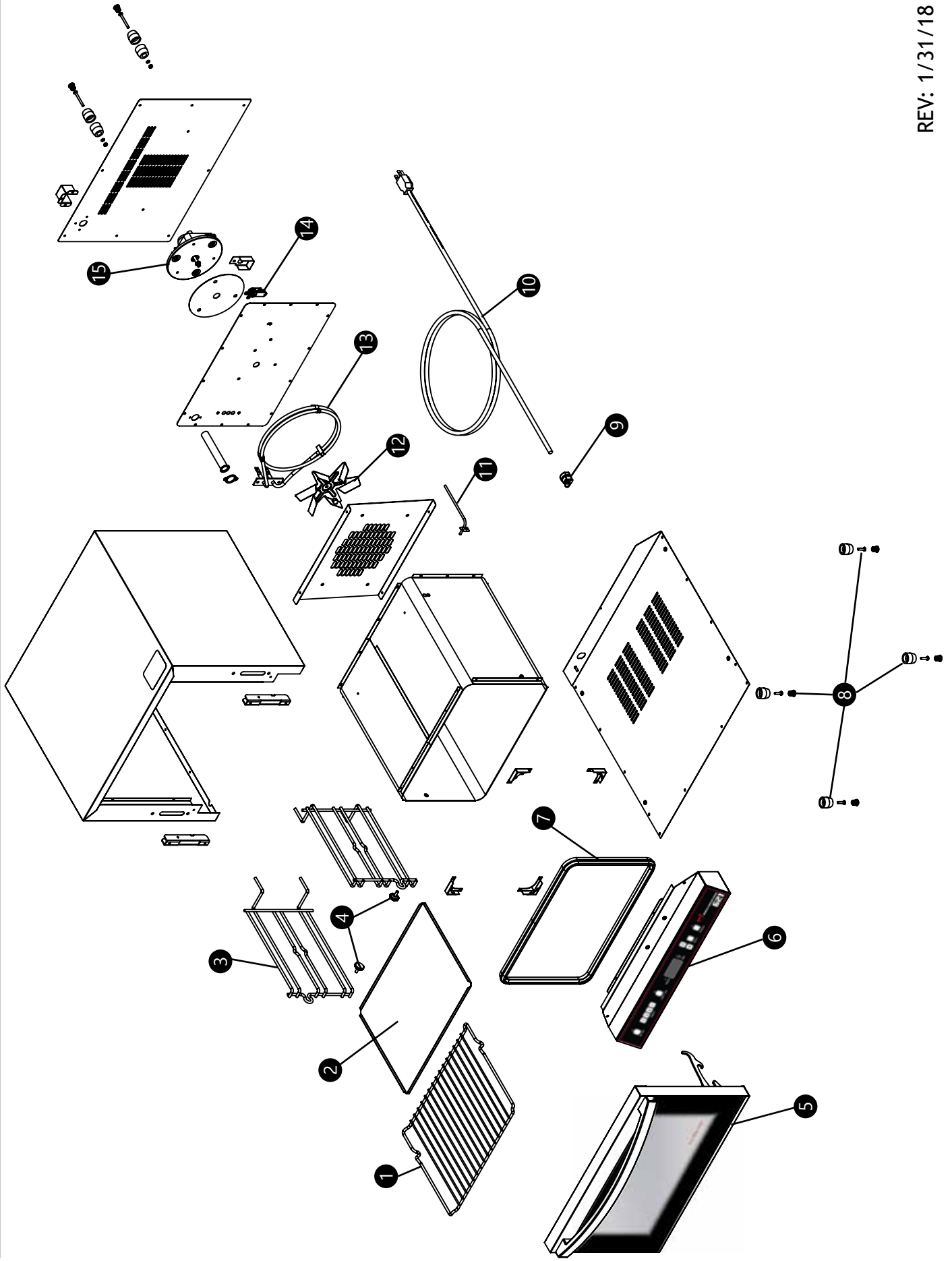

MODEL 621 WIRING DIAGRAM:

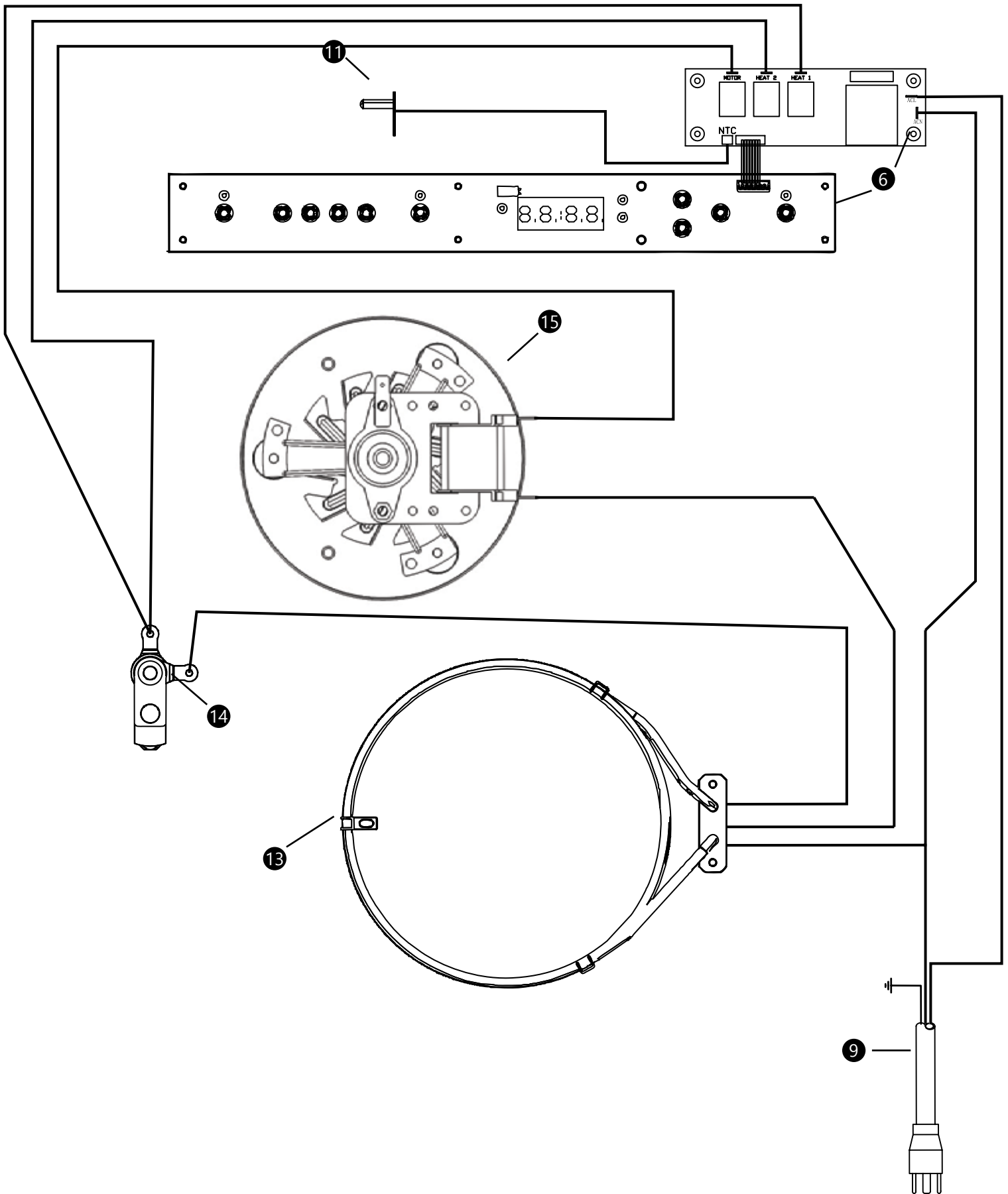

MODEL 621/721: TROUBLESHOOTING

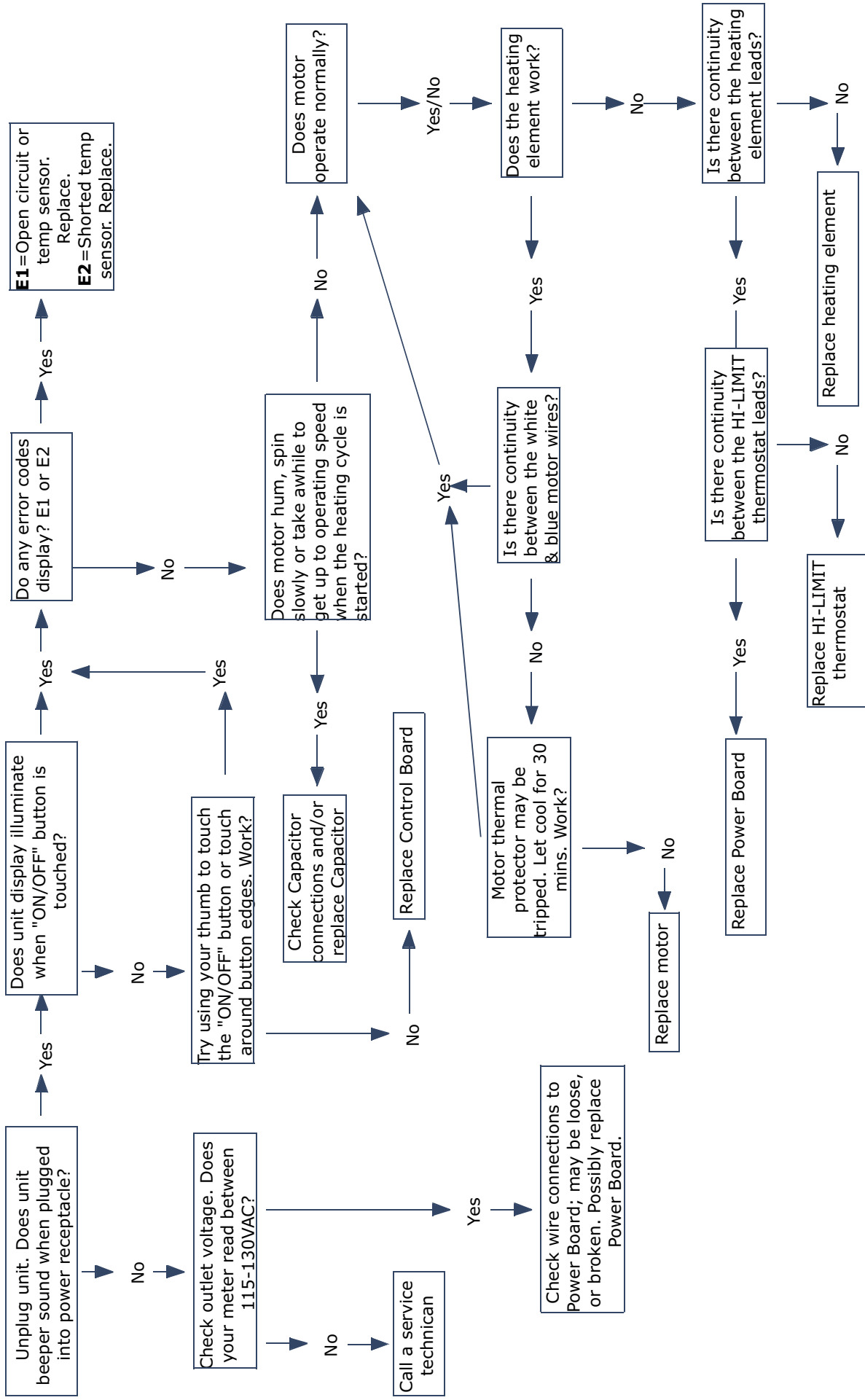

DON'T FORGET THE PARCHMENT PAPER!

**It makes for easy clean up!
Best of all - it's pre-cut to your pan size!**

Model 721 Convection Oven Parchment Paper

(1000 Sheets) Item #0027258-1000

(500 Sheets) Item #0027258-500

Additional Set of 3 baking pans: Item #00721PS3

Model 620/621 Convection Oven Parchment Paper

(1000 Sheets) Item #0022694

(500 Sheets) Item #0022693

Additional Set of 3 baking pans: Item #00620PS3

Model 520 Convection Oven Parchment Paper

(500 Sheets) Item #0022847

Additional Set of 3 baking pans: Item #00520PS3

NEED A COOLING RACK?

Model 721 Cooling Rack

Item #0027359CR

Model 520/620/621 Cooling Rack

Item #0022840CR

Please visit our website or give us a call:

www.wiscoind.com

1-800-999-4726

1 YEAR REPLACEMENT/EXCHANGE

Wisco Industries, Inc. warrants its equipment against defects in materials and workmanship subject to the following conditions:

Should any product fail to function in its intended manner under normal use within the limits defined in this warranty, Wisco Industries will determine if the item is to be repaired or replaced by Wisco Industries. Failure to follow authorizing instructions may void any claim and/or warranty.

* Contact Wisco Industries for repair/replacement by calling (608) 835-3106 or toll free (800) 999-4726.

You can also email us at: contact@wiscoind.com

* An authorizing RMA# must be obtained through Wisco Industries BEFORE any warranty issues can be resolved. Failure to do so in advance may void the warranty/claim resulting in Wisco Industries not being responsible for any incurred expenses and/or charges.

* At time of call Wisco Industries will assist you in:

- getting your unit replaced/exchanged
- and/or obtaining repair parts
- and/or authorizing a service agent

This warranty covers products shipped into the 48 contiguous United States, Hawaii and metropolitan areas of Alaska only. Warranty for international or areas not listed above will consist of replacement of parts only. There will be no labor coverage and parts must be shipped to an address within the 48 contiguous United States, Hawaii or metropolitan areas of Alaska only.

Time Period

One year from date of shipment from our manufacturing facility. Parts replaced under this warranty are warranted for the un-expired portion of the original product warranty only.

Exclusions

The following conditions are not covered by warranty:

- Equipment failure relating to improper installation and improper utility connection or supply.
- Equipment that has not been properly maintained or damage from improper cleaning and/or water damage to controls.
- Equipment that has not been used for its intended purpose or has been subject to misuse or misapplication, neglect, abuse, accident, alteration, negligence, damage during subsequent transit, delivery or installation, fire, flood, riot or act of god.
- Equipment that has the model number or serial number removed or altered.

WISCO INDUSTRIES, INC. DISCLAIMS AND EXCLUDES ANY AND ALL OTHER EXPRESS OR IMPLIED WARRANTIES, INCLUDING WITHOUT LIMITATION, ANY AND ALL WARRANTIES OF MERCHANTABILITY OR FITNESS FOR A PARTICULAR PURPOSE.

Buyer agrees that its SOLE AND EXCLUSIVE REMEDY against Wisco and Wisco's SOLE AND EXCLUSIVE LIABILITY arising out of any defect or nonconformity in the product shall be replacement/exchange of such nonconforming countertop food service equipment at Wisco's expense. No countertop food service equipment shall be returned without Wisco's consent. IT IS AGREED THAT WISCO'S MAXIMUM LIABILITY SHALL NOT IN ANY CASE EXCEED THE SALE PRICE FOR THE COUNTERTOP EQUIPMENT CLAIMED TO BE DEFECTIVE OR NONCONFORMING.

Without limiting the generality of the foregoing, SUCH WARRANTIES DO NOT COVER: Glass, plastic enclosures/panels, door assemblies, hardware, light bulbs & wire pizza oven heating elements.

SHIPPING DAMAGE

If the outside packaging of your order is visibly dented, crushed, torn or otherwise significantly damaged, or if you move the carton and you hear broken glass, please reject the shipment while driver is still with you if possible. Please call us at (800)999-4726 or email contact@wiscoind.com to notify us of the issue. We will confirm the damage with the carrier and re-ship your order immediately.

RETURN POLICY

You may return any unused, undamaged items within 30 days of receipt at your expense. We will issue a refund in the form of your original payment, less a 20% restock fee. Wisco Industries will not reimburse any shipping and handling fees. All returns must be received in resalable condition. Wisco Industries will not accept a return with shipping damage.

If you would like to return an item please call us at 608-835-3106 or toll free at 1-800-999-4726 and ask for our Food Service Equipment Division or you may send an email to us at: contact@wiscoind.com You will be given a return # and return instructions. We can not accept returns without a return #. Please be sure to include a copy of the packing list with the return.